



## Pressure Sensor with Ceramic Sensor Element



measuring  
•  
monitoring  
•  
analysing

SEN-96



- Gauge pressure
- Measuring range:  
-1...0 to 0...600 bar
- Temperature (medium):  
Max. 85 °C
- Non-linearity:  
0.5 %
- Material:  
Stainless steel and ceramic



KOBOLD companies worldwide:

ARGENTINA, AUSTRIA, BELGIUM, BULGARIA, CANADA, CHILE, CHINA, COLUMBIA, CZECHIA, DOMINICAN REPUBLIC, EGYPT, FRANCE, GERMANY, GREAT BRITAIN, HUNGARY, INDIA, INDONESIA, ITALY, MALAYSIA, MEXICO, NETHERLANDS, PERU, POLAND, ROMANIA, SINGAPORE, SOUTH KOREA, SPAIN, SWITZERLAND, TAIWAN, THAILAND, TUNISIA, TURKEY, USA, VIETNAM

KOBOLD Messring GmbH  
Nordring 22-24  
D-65719 Hofheim/Ts.  
Head Office:  
+49(0)6192 299-0  
+49(0)6192 23398  
info.de@kobold.com  
www.kobold.com

**Description**

The KOBOLD SEN-96 Standard model is an electronic transmitter with ceramic sensor for air, industrial, technical gases and water and oil, designed to be installed in gas distribution plants, on bottles, on refrigerators, on compressors, on vacuum pumps and hydraulics and water high pressure plants. It is ideally suited to be used in the industry in general, in the gas stocking or machines production, in light or heavy pneumatics industry, in the refrigeration industry, in welding and vacuum.

**Technical Data**

- Ranges: 0 ... 1/0 ... 600 bar, relative, -1 ... 0/-1 ... +24 bar, relative
- Accuracy:  $\leq \pm 1.0\%$  of the range\*
- Non-linearity (BFSL):  $\leq \pm 0.5\%$  of the range, according to EN 61298-2
- Non-repeatability:  $\leq 0.1\%$  of the range, according to EN 61298-2
- Output signal deviation of zero:  $\leq \pm 0.5\%$  of span, typical;  $\leq \pm 0.8\%$  of span, max.
- Thermal drift: Between 0 and 80 °C, 1 % of span; 2.5 % of span, max.
- Long term drift:  $\leq 0.2\%$  of span, according to EN 61298-2
- Process fluid temperature, ambient and stocking temperature: -25...+85 °C
- Output signals: 4... 20 mA, 0...5 V<sub>DC</sub>, 0...10 V<sub>DC</sub>, 1... 5 V<sub>DC</sub>, 0.5... 4.5 Ratiometric v<sub>DC</sub>
- Response time: <4 ms
- Emission and immunity: According to EN 61326, (group 1 - class B; industrial applications)
- Process connection: In AISI 316L, hole  $\varnothing$  2.5 mm
- Sensor: Ceramic in Al<sub>2</sub>O<sub>3</sub>
- Case: In AISI 316L, vented up to 16 bar
- Gasket (Sensor): FKM
- Electric connection: EN 175301-803 Form A
- Protection degree: IP 65 according to IEC 529 / EN 60529\*\*
- Weight: 0.12 kg

\* Including non-linearity, hysteresis, non-repeatability and output signal deviation of zero at the reference conditions described in standard EN 61298-1

\*\* with properly assembled electric connection .

Ranges bar, relative	Overpressure bar, relative
-1 ... 0	5
-1 ... 0.6	5
-1 ... 1.5	5
-1 ... 3	8
-1 ... 5	12
-1 ... 9	20
-1 ... 15	32
-1 ... 24	50
0...1/0...1.6/0... 2.5	5
0 ... 4	8
0 ... 6	12
0 ... 10	20
0 ... 16	32
0 ... 25	50
0 ... 40	80
0 ... 60	120
0 ... 100	200
0 ... 160	320
0 ... 250	500
0 ... 400	600
0 ... 600	800

Other ranges available on demand. Units of measurement available in psi, MPa, kPa too

**Dimensions (in mm)**

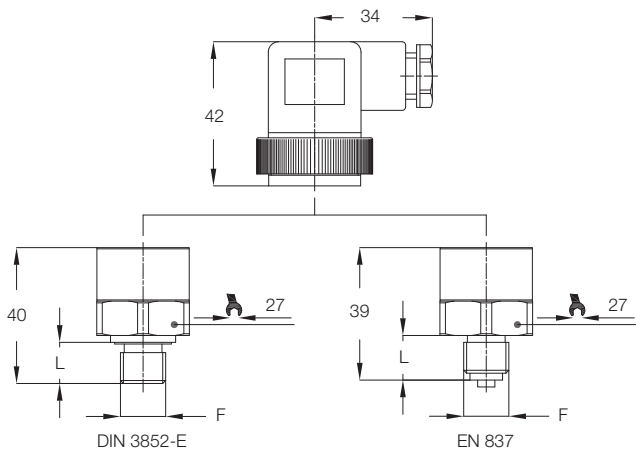

F <sup>1)</sup>	L (mm)
A - G ½, male EN 837	20
B - G ¼, male EN 837	13
E - G ¼, male DIN 3852-E <sup>2)</sup>	13
F - ½ - 14 NPT	20
G - ¼ - 18 NPT	13

<sup>1)</sup> Torque 20...30 Nm

<sup>2)</sup> For pressures up to 400 bar

**Wiring Diagram**

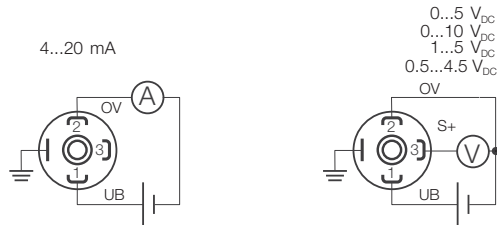

**Order Details** (Example: **SEN-9601 0 B075 A 0**)

Model	Output	Measuring range	Mechanical Connection	Options
<b>SEN-9601...</b>	...0... = 4 - 20 mA, 2-wire <b>(standard)</b>  ...1*... = 0 ... 5 V <sub>DC</sub> (8 ... 30 V <sub>DC</sub> )  ...2*... = 0 ... 10 V <sub>DC</sub> (14 ... 30 V <sub>DC</sub> )  ...3*... = 0.5 ... 4.5 V <sub>DC</sub> ratiometric (5 V <sub>DC</sub> ± 10%)  ...4*... = 1 ... 5 V <sub>DC</sub> (8 ... 30 V <sub>DC</sub> )	<b>C 315</b> = -1 ... 0 bar <b>C 505*</b> = -1 ... 0.6 bar <b>C 515*</b> = -1 ... 1.5 bar <b>C 525*</b> = -1 ... 3 bar <b>C 535*</b> = -1 ... 5 bar <b>C 545*</b> = -1 ... 9 bar <b>C 555*</b> = -1 ... 15 bar <b>C 565*</b> = -1 ... 24 bar  <b>B 025</b> = 0 ... 1 bar <b>B 035</b> = 0 ... 1.6 bar <b>B 045</b> = 0 ... 2.5 bar <b>B 055</b> = 0 ... 4 bar <b>B 065</b> = 0 ... 6 bar <b>B 075</b> = 0 ... 10 bar <b>B 085</b> = 0 ... 16 bar <b>B 095</b> = 0 ... 25 bar <b>B 105</b> = 0 ... 40 bar <b>B 115</b> = 0 ... 60 bar <b>B 125</b> = 0 ... 100 bar <b>B 135</b> = 0 ... 160 bar <b>B 145</b> = 0 ... 250 bar <b>B 155</b> = 0 ... 400 bar <b>A 165*</b> = 0 ... 600 bar	<b>A</b> = G ½, male <b>(standard)</b>  <b>B*</b> = G ¼, male  <b>E*</b> = G ¼ DIN 3852-E, male  <b>F*</b> = ½" NPT, male  <b>G*</b> = ¼" NPT, male	<b>0</b> = without <b>Y*</b> = special option (specify in clear text)

\* minimum order quantity = 20 pieces per item (identical model code)

Output signal code	4 ... 20 mA 0	0 ... 5 V <sub>DC</sub> 1	0 ... 10 V <sub>DC</sub> 2	0.5 ... 4.5 V <sub>DC</sub> ratiometric - 3	1 ... 5 V <sub>DC</sub> 4
No. of wires	2	3	3	3	3
Load max. (Ω)	$R_L \leq (V_{in}-8)/0.02$	$R_L \geq 5 \text{ K}\Omega$	$R_L \geq 10 \text{ K}\Omega$	$R_L \geq 4.5 \text{ K}\Omega$	$R_L \geq 5 \text{ K}\Omega$
Supply: +Vin (V <sub>DC</sub> )	8 ... 30	8 ... 30	14 ... 30	5 ± 10%	8 ... 30
Absorbed current (mA)	< 25	< 10	< 10	< 10	< 10

All output signals are provided of protection against short circuit and polarity inversion. Insulation tension 500 V<sub>DC</sub>